

Make the cut

with Wanner granulators



Baby

The granulator for small sprues and lab applications

Compact

The universal beside-the-press granulator with a wealth of advantages

CLE

The particularly quiet universal granulator

Xtra

The specialist for brittle materials

Dynamic

The universal granulator for massive parts and bulky sprues

Energy

The central granulator for large-volume parts and high throughput

Thermo Granulator

The compact regranulator system



Superior granulators – made in Germany



Every Wanner granulator is the product of many years of expertise and practical solutions in plastics recycling. Whether they're used to grind sprues and defective parts, blow-moulded products or extruded profiles – granulators from Wanner are sure to meet your requirements reliably over the long term while producing outstanding granulating results – **even under the harshest conditions.**





Wanner Technik GmbH, Wertheim-Reicholzheim...



...the grinding technology experts!

The right solution for every application

Used as beside-press granulator or centralised granulator, as granulator for edge-trim or as granulator integrated into an injection moulding machine, every one of our plastic granulators developed and produced in Germany contains the experience gained in many years of activity in the field of plastic recycling.

Our focus is, to make our machines as easy-to-use and reliable as possible.

The source of our expertise is our effort to see everything through the eyes of our customers and to find innovative and simple solutions for special problems - from practical expertise to practical use. If you should need more information about our granulators or with regard to size reduction of plastic scrap, please do not hesitate to contact us or visit our web-site.

We look forward to **your specific request:** +49-9342-3088-0

info@wanner-technik.de

www.wanner-technik.de

The energy saving controls for granulators



Power when you need it!



Exploit optimisation potential in the sprue cycle

The advantages of a closed sprue cycle directly at the injection moulding machine are obvious.

- > The process can be automated very well and material mixing is avoided.
- > At the end of the injection moulding process, almost 100% of the processed plastic is inside the products.

In addition, there is considerable potential for energy savings, since granulators processing small sprues at long cycle times often operate in idle mode.

Optimum drives for alternating load

We use drives optimised for partial load in our beside-the-press granulators. According to the standard, the usual energy efficiency classes for electric motors are only defined for the case that the electric motor is operated at nominal power. However, the fact that a granulator with a 3 kW drive motor actually requires 3 kW of power is hardly ever the case and only rarely occurs in a granulator application with automated feeding. The use of drives that are optimised for partial load therefore results in significant savings potential:

- > The magnetisation losses and thus the energy consumption in no-load operation can be significantly reduced (up to over 40%).
- > The maximum power that can be called up for a short time is retained, but at a lower efficiency than with systems designed strictly according to IE classification.

The C-series drives we use are optimised for operation as press side granulators and save a considerable amount of energy compared to conventional „energy-efficient“ drives, without compromising on maximum power.



**GREEN
LINE**

Power - when it is needed. The Green-Line control system

The energy efficiency of an beside-the-press granulator can be increased, if it is only operated when necessary. If the required hourly throughput is 5 kg/h and the granulator can grind 20 kg/h, then it is sufficient to operate the granulator only about 25 % of the time. Start/stop operation can thus demonstrably save up to 75% of energy.

The Green-Line control with integrated automatic start/stop allows the granulator to run only as long as the process requires and reduces energy costs in the long run, protects the environment and usually pays for itself within the first year.

- > The length of the operating and pause times can be easily adjusted via potentiometer or via a signal input from the injection moulding machine.
- > Modern control technology with solid-state relays guarantee safe operation for many years.
- > High-torque drives with high starting torque ensure reliable start-up, even with many sprues in the cutting chamber.
- > The stop time can easily be extended over several injection cycles; depending on the process, energy savings of over 75 % are possible.



5

The intelligent way to save energy. The IQ control system

The IQ control offers a range of options to save energy. All granulators with IQ control are equipped with frequency converters. The speed of the granulator can be easily adjusted to the requirements of the respective injection process via the touch screen of the control system. Halving the speed almost halves the power consumption of the machine. In addition, the IQ control system contains an operating mode that includes a start-stop functionality similar to the Green Line function. The operating and pause times are set in seconds via the touch display.

Via the integrated OPC-UA interface, the control provides relevant data on the actual energy consumption, the operating states as well as information regarding operating times and any necessary maintenance intervals.

With this control system, you save energy and are optimally equipped for Industry 4.0 requirements.



The **B**aby Series

The granulator for small sprues and lab applications



The Baby Series is perfectly suited for small sprues and granulating tasks in the lab.

There are two basic models available within the series: A standard model with suction box for production and a lab model with a granulate drawer to collect ground stock.

Various hoppers and stands also make it easy to further adapt the granulator to specific tasks.

Its compact design with a gear motor takes up minimal space. This makes the baby granulator outstanding for installation in small injection moulding machines and sorting systems.

The Baby Series is the perfect solution for micro injection moulding with small throughputs of up to about 3 kg/h.

Model B 08.10 Standard >





Advantages



- > Optimised cutting geometry yields high-quality ground stock
- > Low rotor rotation speed and solid construction make it very quiet
- > Compact design takes up minimal space
- > Extremely easy to open and clean – ideal for applications requiring frequent material changes and for lab applications
- > Low energy usage means low operation costs

Technical Data



B 08.10

Cutting chamber opening	80 x 100 mm ²
Rotor diameter	90 mm
Rotor knives	9
Stator knives	2
Motor power	0,75 kW
Weight	40 kg

(All dimensions in mm, rounded, subject to technical modifications)



< B 08.10 Lab design

For applications in the lab, we offer the baby granulator with a closed drawer where the ground stock produced is collected. The drawer can be easily taken out without opening the cutting chamber. For cleaning purposes, the top part of the cutting chamber together with its hopper can be easily removed, thus exposing the rotor and cutting chamber completely.

Dimensions

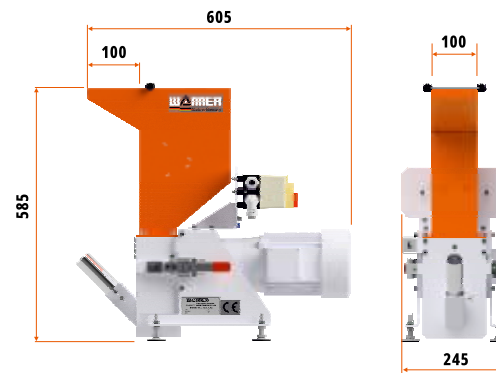

B 08.10 Granulator completely open ▲



< B 08.10 On high stand

Our baby granulator is also available in various designs, e.g. with a feed hopper for robot feeding (no illustration), on a high stand (see image) or with various special feed hoppers. This makes it easy to adapt our smallest granulator to your needs. The Baby Series is the perfect granulator to handle small sprues and small throughputs.

The Compact Series

The universal beside-the-press granulator with a wealth of advantages



Model C 17.26f with robot feed hopper >

Our best-selling beside-the-machine granulator.

Three cutting chamber sizes with three different power levels facilitate seamless processing of sprue sizes and plastics types typical for injection moulding. Its innovative machine concept allows users to effortlessly clean the cutting chamber by swiveling the hopper and the upper part of the cutting chamber to the side, giving fast, easy access. This makes the work just a bit easier for users, thus enhancing productivity.

Special cutting geometry granulates sprues and rejected parts into high-quality ground stock.

The modular design, compact construction with a sturdy gear motor drive and the variety of options available make it very easy to adapt the machine to any customer requirement.

An optional energy-efficient green line and IQ-Line control unit dramatically reduces the energy consumed during operation for typical applications.



Advantages



- > Can be used universally for a wide variety of applications and materials
- > A wealth of options such as various hoppers, trolley stands and control unit types facilitate optimal adaptation to your unique needs
- > Very compact construction made possible by a robust gear drive taking up very little space
- > Low rotor rotation speed and construction designed to minimize structure-borne noise make it very quiet
- > Easy and simple to open and clean in seconds. Good accessibility allows for fast material changes and easy servicing
- > The cutting geometry yields high-quality ground material and is suitable for all plastics, from soft to hard and reinforced or not reinforced
- > Low energy consumption – innovative energy-saving control unit **Green Line** or **IQ** optionally available
- > Maximum performance for your money

Technical Data



	C 13.20	C 17.26	C 17.31
Cutting chamber opening	130 x 200 mm ²	170 x 260 mm ²	170 x 320 mm ²
Rotor diameter	140 mm	170 mm	220 mm
Rotor knives	9	12	12
Stator knives	2	2	2
Motor power	2,2 kW	3 kW / 4 kW	4 kW
Weight	125 kg	155 kg	165 kg

**GREEN
LINE**



< The Green-Line control and the IQ control are in all models of C series available

Standard

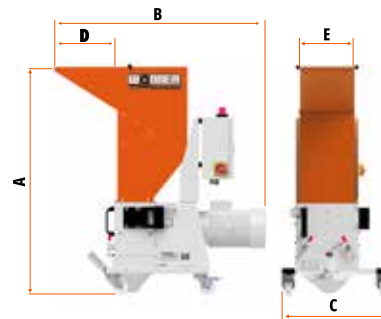

Robot infeed hopper

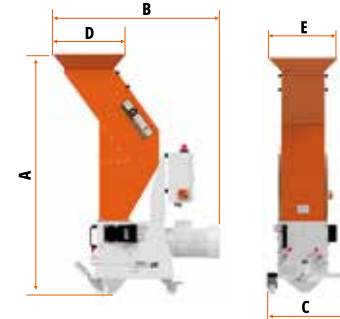

High stand

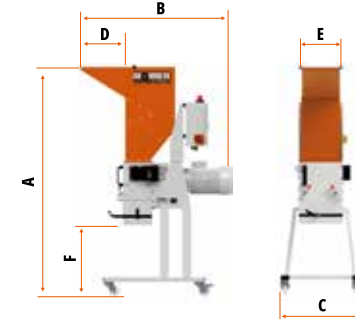

Dimensions

	C 13.20	C 17.26	C 17.31		C 13.20	C 17.26	C 17.31		C 13.20	C 17.26	C 17.31
A	890	1090	1170	A	1390	1430	1475	A	1380	1560	1640
B	755	1020	980	B	895	990	990	B	800	1020	980
C	415	520	520	C	415	520	520	C	560	560	660
D	245	290	290	D	415	430	430	D	245	290	290
E	205	255	305	E	375	415	445	E	205	255	305
								F	490	485	485

(All dimensions in mm, rounded, subject to technical modifications)

1 – 2 – 3 – Open!



First pull out the suction box to the front to open the granulator.



Open the cutting chamber unlocking the quick release clamp and push open toward the front. Supported by a massive hinge, the grinding chamber and in-feed hopper can be swivelled all the way to the side.



Rotor and screen cradle are fully accessible and freely visible. The screen can be removed easily with one hand. Undercuts, where material has the potential to collect, are kept to a minimum. Cleaning the granulator is quick and easy.



Control unit

Standard hopper

Robot feed hopper with sprue collecting funnel

Cutting chamber with gear motor

Rotative fill-level sensor

trolley stand with spacers and large suction box

Dedusting unit

High stand with sack filling box

Standard trolley stand with suction box

C 17.26 Standard

The C-series granulators are ideal beside-the-machine granulators. Easy handling, easy cleaning, small footprint, and great design variety guarantee that you will find the optimal solution for every application. The model shown here with a small standard hopper is especially well-suited to conveyor belt feeding. A suction pipe for hose ND40 comes standard with all C-series granulators.

▲ Der C-Serien Baukasten bietet viele Optionen



C 17.26 Robot feed hopper

The models of the C Series with robot feed hopper are ideal for feeding with sprue picker or robot. A large infeed opening and extra sprue collecting funnel ensure that freefalling sprues are fed into the grinding chamber reliably. Sandwich sheets used for all hoppers offer outstanding noise reduction. The hopper can be installed on the granulator rotated 180°.



C 17.26 Highstand

We also have solutions well-suited for applications where the regrind material is not automatically fed back into the injection process. With granulators mounted on high stand, the ground stock can simply be collected in a sack under the granulator that can later be removed and tied off. The gear drive and cutting chamber are designed to be tough and are capable of handling larger quantities fed in all at once.



C 17.26 Integrated dedusting unit

If the regrind material needs to be virtually free of dust, our model with integrated dedusting system is the perfect fit. Especially when it comes to the granulating of very brittle glass-filled materials, it is often nearly impossible to achieve ground stock without a certain amount of fine dust. The dust extraction box integrated below the granulator reliably takes out these fine particles and separates them out into another bin. High-quality ground stock remains, ready to be processed further right away.



C 17.26 With auger chute

Our solution for 3-plate tools when the sprue falls out of the tool directly into the auger chute. The large dimensions of the infeed auger ensure that large sprues are processed reliably. For safety, the granulator is delivered with an additional limit switch that must be mounted on the safety door of the injection moulding machine or with an interface to be connected to the control unit circuit of the injection moulding machine.



C 13.20 Special chute for separation devices

Our solution for separation applications, during which small parts are collected below the separation drum while the parts are conveyed through the drum to the granulator. Also good for use: The granulator is positioned under the separation drum and the parts are collected at the drum output (no image). Individualised customer solutions are our strength.

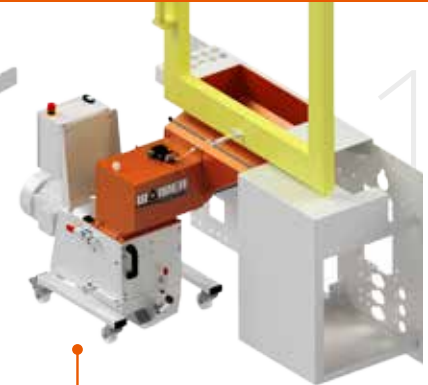

C 17.26 Special hopper for Arburg injection moulding machines

For most standard injection moulding machine types with integral sprue pickers, we have a solution that ensures the sprue removed can be fed reliably to our granulators. This image shows an example of a solution for a feed-hopper suitable for an Arburg injection moulding machine. Identical solutions are available for Engel and Sumitomo Demag injection moulding machines as well. Solutions that are sure to work.

The **CLE**-Series

Compact Low Noise Emission – The particularly quiet universal granulator

WANNER
Wanner Technik GmbH



Model CLE 23.35 with sprue picker hopper >

When processing hard and brittle, solid GF-reinforced sprues, usual knife-type granulators are often quite noisy. Usually, this noise problem is addressed by using an integrated sound enclosure mounted to the granulator. However, this enclosure often restricts accessibility during cleaning and requires additional space.

When developing the CLE series, we took a different approach to the noise problem: **We have reduced the noise emission by taking constructive measures on the cutting chamber and the chassis, to dampen the structure-born noise and vibrations.**

The results can be heard and seen! Depending on the processed material, the noise reduction improves significantly, even better than using an integrated soundproof enclosure. As always, the cutting geometry adopted from our C-series delivers a very high-quality, uniform, and low-dust regrind. The CLE granulator is also available with the Green-Line and IQ-Line energy-saving control, which guarantees a particularly economical operation. **Would you like to hear a little sample?**



13

Advantages



- > Universally applicable for various plastics and a wide range of demands
- > Significantly reduced noise emission when grinding brittle, hard GF-reinforced plastics compared to other available granulators
- > Comparison measurements with other available beside-the-press granulators show a reduction of the sound level by up to 9 dB(A), which is approximately the noise level of a screenless type of crusher granulator
- > Many available options allow an optimal adaptation to your requirements
- > Easy handling and a good accessibility make cleaning and material changes simple
- > High-quality regrind due to an optimized cutting geometry for all plastics – from soft to hard and reinforced
- > Low energy consumption – innovative **Green-Line** or **IQ-Line** control available
- > Optimal for demanding applications

Technical Data



CLE 23.35

Cutting chamber opening	230 x 350 mm ²
Rotor diameter	170 mm
Rotor knives	12 + 12
Stator knives	2 + 2
Motor power	3,0 kW
Weight	340 kg

Comparative tests

The noise development when shredding plastics is very dependent on the product to be shredded. We have compared our new Wanner CLE with other available granulators when grinding various materials and have obtained these results:

Material	Noise reduction*
PA 6.6 GF / rod Ø 8 mm	-9 dB(A)
Sprue ABS / rod Ø 8 mm	-5 dB(A)
Sprue PP / rod Ø 8 mm	-3 dB(A)

*CLE compared to the reference granulator.

Standard

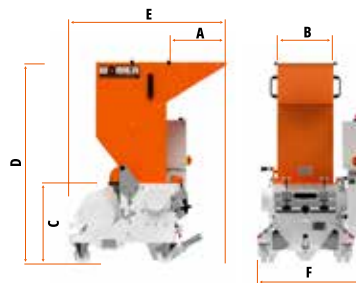

Sprue picker hopper

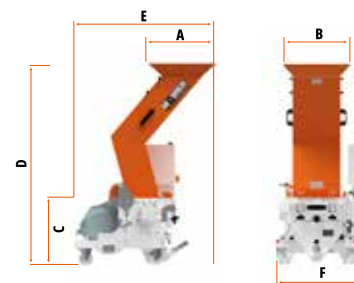

On high stand

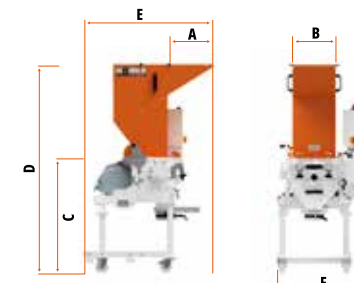

Dimensions

CLE 23.35 Standard		CLE 23.35 Sprue picker hopper		CLE 23.35 On high stand	
A	300	A	500	A	300
B	346	B	500	B	346
C	495	C	495	C	943
D	1250	D	1488	D	1698
E	979	E	1035	E	1038
F	693	F	687	F	687

(all dimensions in mm, rounded, subject to technical modifications)



www.wanner-technik.de/en/granulators/cle

Find even more info and pictures of the CLE on our website

The Xtra Series

The specialist for brittle materials



The screenless type of crusher granulators of the Xtra Series were conceived as **beside-the-machine granulators for applications with brittle and fibreglass-reinforced plastic materials.**

The Xtra Series is available in 3 cutting chamber sizes, with the smallest cutting chamber having one, the mid-sized cutting chamber having two, and the largest cutting chamber having three primary crushers. The star-shaped primary crushers process larger sprues and parts until they are small enough to fall into the toothed rollers and are granulated to their final grain size. Granulate size is determined by the size of the teeth on the toothed rollers, with tooth widths 4 and 5 mm available.

A low rotor speed of just 30 rpm. reduces the amount of noise compared to standard knife granulators.

We developed the Xtra Series to have a very compact construction and for easy handling. The grinding chamber can be fully opened with ease and without the use of tools, making it simple to clean these machines quickly.

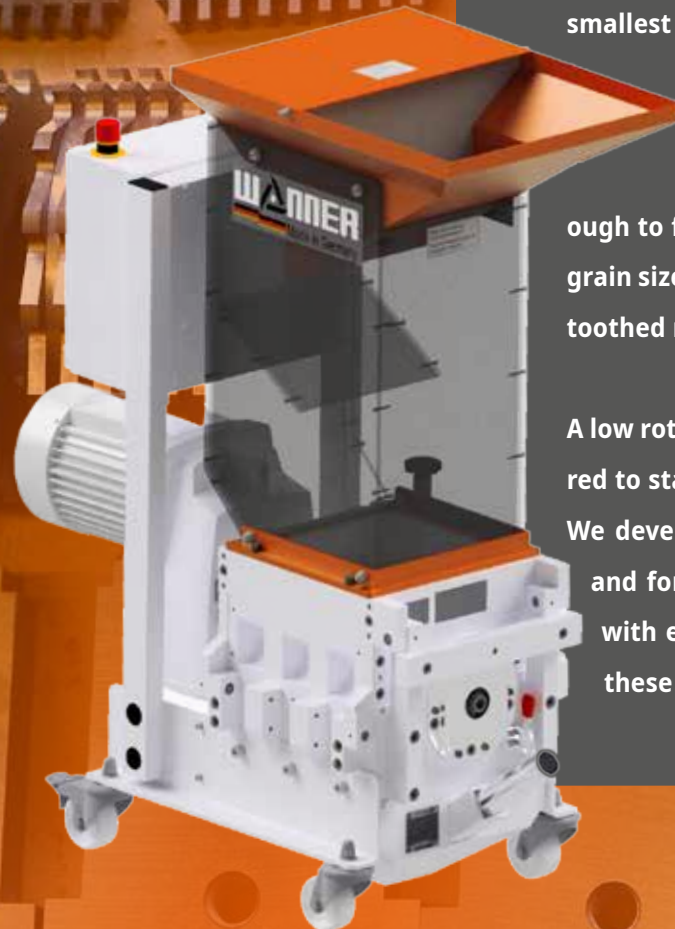

Model Xtra 2 >





Advantages



- > Low noise due to the very low rotation speed
- > Uniformly shaped and almost dust-free ground stock
- > Small footprint thanks to direct drive with gear motor
- > Various hoppers and stand types make it easy to adapt to your needs
- > Low energy consumption made possible by gear motor with strong torque
- > Innovative **Green-Line**  or **IQ-Line**  energy-saving control unit available as an option

Technical Data



	Xtra 1	Xtra 2	Xtra 3
Cutting chamber opening	260 x 170 mm ²	260 x 260 mm ²	260 x 350 mm ²
Rotor blade rollers	2	3	4
Primary crusher	1	2	3
Rotor speed	32 rpm	32 rpm	32 rpm
Cutting modul	4 - 5 mm	4 - 5 mm	4 - 5 mm
Motor power	1,1 kW	1,5 kW	2,2 kW
Weight	200 kg	220 kg	250 kg

**GREEN
LINE**



< The Green-Line control and the IQ control are in all models of XTRA series available

15

Standard

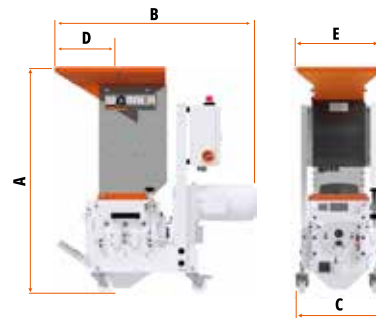

Sprue picker hopper

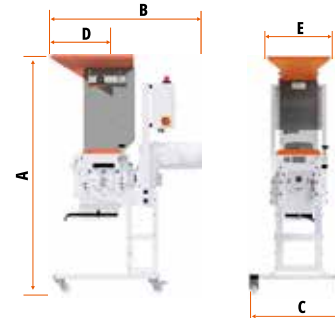

On high stand

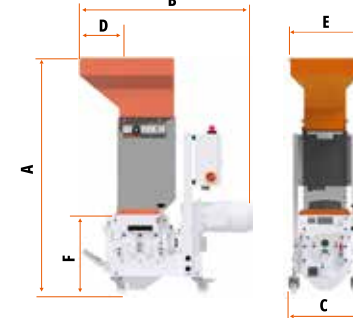

Dimensions

	Xtra 1	Xtra 2	Xtra 3	Xtra 1	Xtra 2	Xtra 3	Xtra 1	Xtra 2	Xtra 3
A	945	1105	1200	1300	1350	1400	1410	1575	1625
B	900	985	1125	990	985	1035	960	990	1125
C	425	425	425	425	425	425	660	660	660
D	200	290	290	300	300	290	200	300	290
E	330	400	400	400	400	400	330	400	400

(All dimensions in mm, rounded, subject to technical modifications)



1

Easy to open – easy to clean.

To open the granulator, pull out the suction box.



2

Open the locking screw on the side and tip the hopper to the frontside.



3

Open the frame with the stator knives, then the toothed rollers and the primary crushers are freely accessible.

Undercuts in the cutting chamber where material can collect are reduced to a minimum.

The rotor can be turned to clean the toothed rollers.

Cleaning the granulator is also quickly done with our Xtra series!



Standard hopper made of sandwich sheet metal

Standard hopper from PC

Robot infeed hopper from PC

Robot infeed hopper from sandwich sheet metal

Standard control

Control with additional options

Cutting chamber with gear motor

Dedusting unit for Xtra series

Drehflügelmelder

Standard trolley stand with suction box

High stand with sack filling box

raised chassis with large suction box and optional level sensor

▲ The modular system makes it very easy to design the machine for special needs

XTRA2 Standard

The screenless tooth roller granulators are ideal for hard and brittle materials.

The machines of the Xtra series are very compact and due to the low speed they are quieter than e.g. our C-series granulators, especially for thick-walled, hard and brittle parts.

The standard version with a low hopper with integrated baffle is suitable for feeding via a conveyor belt; the regrind can be fed directly back to the injection moulding machine via the suction box.



XTRA2 with robot infeed hopper

Ideal for feeding with sprue picker or robot. The large hopper opening and the straight inlet ensure that even large, free-falling sprues are safely fed into the cutting chamber. The hopper is optionally available in sandwich sheet metal, which further reduces the noise level.



XTRA2 Highstand

We also have solutions well-suited for applications where the regrind material is not automatically fed back into the injection process. With granulators mounted on high stand, the ground stock can simply be collected in a sack under the granulator that can later be removed and tied off. The gear drive and cutting chamber are designed to be tough and are capable of handling larger quantities fed in all at once.



XTRA3 with special robot infeed hopper

Thanks to our efficient sheet metal processing, we are able to respond very flexibly to customer requirements. This means that we are also able to supply hoppers that fit your requirements exactly. The example shows a special robot infeed hopper with a particularly large feed opening and special height, especially for very large sprues.



XTRA3 with additional forced feeder

In order to capture very large sprues safely, our XTRA3 model is available with an optional forced feed system that presses large and bulky sprues into the granulator rotor. This significantly reduces the risk of a backlog due to bulky sprues not being pulled in.



XTRA1 with special hopper adapted to a separation system

Our solution for a separating application, where the sprues are falling underneath the drum into the granulator while the parts are conveyed through the drum. Equally convertible: The granulator stands behind the separating drum and the good parts fall out from underneath the separating system. Customised solutions are our strength.



XTRA2 with special hopper for IMM with integral picker

For a large number of injection moulding machine types with integrated sprue pickers or robots, we have a solution that ensures that the removed sprues are granulated in a process-safe manner. We offer solutions especially for injection moulding machines from Arburg, Engel and Sumitomo Demag.

The Dynamic Series

The universal granulator for massive parts and bulky sprues

The machines from the Dynamic Series feature a very robust design and are equipped standard with wear protection components. The cutting geometry with the chevron cutting design of the rotor yields outstanding ground stock, no matter the materials processed.

The Dynamic Series is available in a wide variety of designs. With belt drive and a massive fly wheel, the machines are suitable for larger throughputs and especially massive, thick-wall parts. With its gear drive and low rotor speed, it is especially well-suited for use as a beside-the-machine granulator for especially bulky sprues.

Four different grinding chamber sizes combined with a large selection of various hoppers, trolley stands, control unit options, and accessories make it easy to adapt the machine to meet your unique requirements.

Its large construction makes the machine **especially robust and durable.**

Model 25.38 Standard >





Advantages



- > Its modular design means it can be used universally for a wide variety of applications and requirements
- > Suitable for all standard plastics, from soft to hard and reinforced or not reinforced
- > Highly robust design – for grinding extremely massive parts
- > A wealth of options such as various hoppers, stands, and control unit types facilitate optimal adaptation to your unique needs
- > Comes standard with hardened cutting chamber components protecting against wear
- > Optionally available with integrated sound enclosure
- > Easy and simple to open and clean without any tools
- > Good accessibility allows for fast material changes and easy servicing

Technical Data



	D 25.25	D 25.38	D 25.50	D 30.50	D 25.38 comp	D 25.50 comp
Cutting chamber opening	250 x 255 mm ²	250 x 385 mm ²	250 x 505 mm ²	300 x 500 mm ²	250 x 385 mm ²	250 x 505 mm ²
Rotor diameter	180 mm	180 mm	180 mm	250 mm	180 mm	180 mm
Rotor knives	12	18	24	6	18	24
Stator knives	2	2	2	2	2	2
Motor power	4 / 5,5 / 7,5 kW	5,5 / 7,5 kW	5,5 / 7,5 kW	7,5 kW	4 kW	4 kW
Weight (Standard)	360 kg	410 kg	480 kg	570 kg	370 kg	430 kg

19

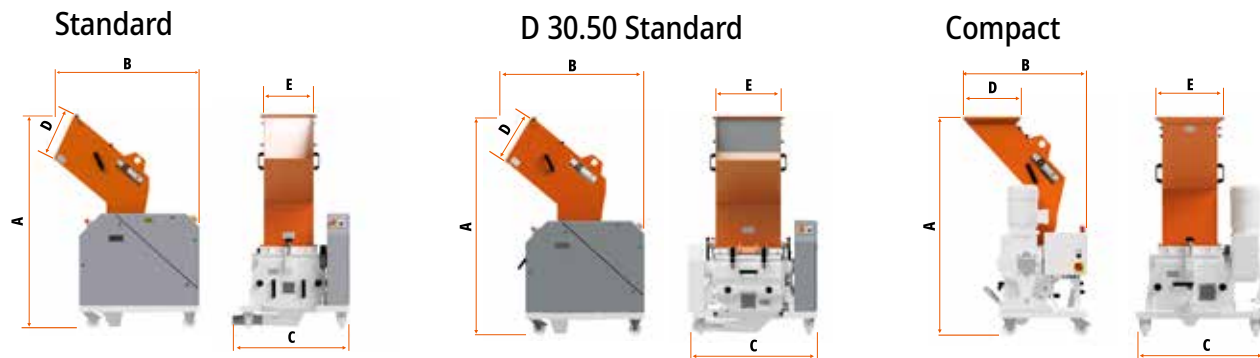

Dimensions	D 25.25	D 25.38	D 25.50	D 30.50	D 25.38 comp	D 25.50 comp
A	1655	1655	1655	1700	1535	1535
B	1120	1120	1120	1085	860	865
C	725	850	970	1005	920	1045
D	360	360	360	390	395	395
E	255	380	500	500	475	595

(All dimensions in mm, rounded, subject to technical modifications)

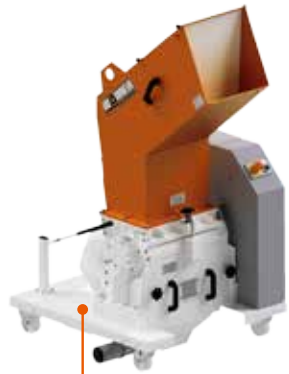

D 25.38 Standard

The D-Series with belt drive is especially well-suited for massive parts and larger throughputs. Depending on the drive, material being processed, and selected screen size, the machine is capable of achieving throughputs of up to 180 kg/h. It comes standard with an ND 80 mm suction pipe, adapters and ND 40 and 50 mm suction pipes are also available.



D 25.38 Compact

The low rotor speed D-Series is developed as a beside-the-machine granulator for especially large sprues. Using a gear motor makes it possible to reduce the rotor speed to 170 rpm - while at the same time maintaining a small footprint compared to machines with belt drives. ND 40 mm suction pipes come standard with the granulator.



D 25.38 High stand with manual feed hopper

This model is designed as a compact central granulator. It facilitates the collection of ground stock directly in a container or sack placed under the granulator. Depending on the drive, material being processed, and selected screen size, the machine is capable of achieving throughputs of up to 180 kg/h. Hardened wear-protected inserts are already integrated into the cutting chambers of machines in the series. Even abrasive materials can be seamlessly processed this way.



D 25.38 Integrated dedusting system

If the regrind material needs to be virtually free of dust, our models with integrated dedusting system are the perfect fit. Especially when it comes to the processing of brittle or fibreglass-reinforced materials, it is often nearly impossible to achieve regrind material without a certain amount of fine dust. The dust extractor box integrated below the granulator reliably takes out these fine particles and separates them out into a separate bin. High-quality ground stock remains, ready to be processed further right away.



D 25.38 Integrated sound enclosure

Most D-series granulators can be equipped with an integrated sound insulating enclosure, covering the cutting chamber, to meet heightened noise level requirements. A full enclosure (without image) is also available. This further reduces the noise level. Depending on the wall thickness of the full enclosure, it is possible to meet almost any requirement.



D 30.50 Standard

The extra large rotor diameter (instead of 180, full 250 mm), this D-series design is outstanding for processing extremely bulky sprues and large, thin-walled blow-moulded objects. Its large rotor diameter ensures rapid capture and secure granulating of light and large parts. The granulator is equipped with a 7.5 kW motor and can be equipped with an additional fly wheel.



D 25.50 Special hopper for long parts

When fed into the machine by a conveyor belt, long parts require a lot of space to tip into the chute. With this type of hopper, for example, blow-moulded parts with lengths of up to 1 m can be reliably fed into the granulator. Adapted gas pressure springs help simplify opening and closing.



D 25.50 Roll feed system and dancer control

Our models with roll feed system are especially well-suited for processing edge trim and film strips. During this process, the roller infeed is adjusted using two-step control and dancer system. As an alternative, analogue inputs are available for superordinate process signals. The roller infeed system is also available in a design for feeding in hoses and flexible pipes.



D 25.50 Special hopper for plates

If, in addition to parts and cut-offs, longer plates also need to be processed, an additional feed chute can be installed on the back of the granulator. This makes it unnecessary to saw and shorten longer plates and profiles before the actual grinding process.



D 25.50 With blower, cyclone and dedusting system

D-series granulators make it easy to build central granulating stations consisting of material transport blowers, cyclone separators, and – if desired – with additional dedusting system or metal separation. Such granulating stations, when processing fibreglass-reinforced sprues and parts for example, can achieve over a ton of throughput per shift - with equally outstanding grinding quality of course. Surface hardening can be optionally performed for the blower when fibreglass materials

will be conveyed. The adjustable height cyclone is equipped with two large hose filters and is dimensioned so that the conveying air does a very good job of separating out from the ground stock, which helps maintain a clean environment. Various different cyclone frames are available to match the height and shape of the container in which the regrind material is collected.



D 25.38 Special hopper for profiles

This special hopper is especially well-suited for processing long profiles in the granulator. The profiles are fed into the machine from the side and then reliably processed by the granulator. Astoundingly massive and intricate profiles can thus be processed in a relatively small granulator. Please keep in mind that the long profiles may project noise into the environment accordingly.

21

The Energy Series

The central granulator for large-volume parts and high throughput



Model E 45.80 Standard >

The E-series granulators are perfectly suited to function as **powerful central granulators** as well as **granulating systems built in-line grinding to process tops and tails** as well as **rejects generated during the manufacture of large blow-moulded parts**.

A total of five cutting chamber sizes as well as various cutting chamber configurations and different feed hopper types allows to adapt the machines specifically to meet the customer's needs and to the type of material feeding.

Granulators in the E Series are equipped with an integrated sound enclosure into which the optionally available material transport blower can be integrated. Furthermore, vibration elements decouple the grinding chamber from the booth, thus dampening the vibrations.

The cutting chamber is designed as a robustly sized structure held together by welding and screws, the rotor shaft runs on oversized bearings.

The granulator's cutting chamber and blower can be accessed quickly and easily without any tools through the wide-opening access doors. Cleaning the granulator is easy.

Advantages



- > Sound enclosure integrated as standard into machines of the series
- > High regrind material quality thanks to Chevron-cutting design
- > Aggressive rotor design for reliable pull-in action of very large parts, optional super-tangential grinding chamber available
- > Five-edged rotor available for extra high throughputs
- > Optional blower can be integrated into the sound enclosure
- > Cutting chamber decoupled from the machine frame and sound insulating booth for effective insulation of the structure-borne noise
- > Extensive accessories available, including various blowers, cyclones, rotative wheel gates, dust removal systems, conveyor belts, and much more

Technical Data



	E 30.50	E 35.40	E 35.60	E 45.50	E 45.80
Cutting chamber opening	300 x 500 mm	350 x 400 mm	350 x 600 mm	450 x 500 mm	450 x 800 mm
Rotor diameter	250 mm	300 mm	300 mm	400 mm	400 mm
Rotor knives	2 x 3	2 x 3 oder 2 x 5	2 x 3 oder 2 x 5	2 x 3 oder 2 x 5	2 x 3 oder 2 x 5
Stator knives	2	2	2	2 optional 3	2
Cut geometry	Chevron cut	Chevron cut	Chevron cut	Chevron cut	Chevron cut
Motor power	7,5 kW - 11 kW	11 kW - 18,5 kW	18,5 kW	18 kW - 30 kW	22 kW - 30 kW
Rotor speed	630 rpm	500 rpm	500 rpm	450 rpm	450 rpm
Weight (Standard)	1000 kg	1300 kg	1450 kg	1850 kg	2200 kg

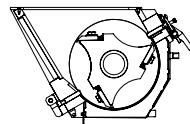

< **Three-edged rotor with standard grinding chamber** – the universal solution for parts and sprues

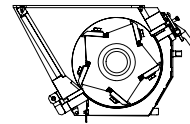

< **Five-edged rotor with standard grinding chamber** – for larger throughputs

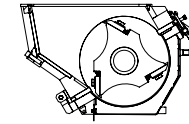

< **Three-edged rotor with super-tangential cutting chamber** – for processing especially voluminous parts

Dimensions

	E 30.50	E 35.40	E 35.60	E 45.50	E 45.80
A	1915	1960	1960	2100	2100
B	1405	1450	1450	1505	1505
C	2250	2320	2320	2520	2520
D	1625	1760	1760	1745	1745
E	1000	960	1260	1100	1540
F	505	430	630	510	810
G	430	430	430	545	545

(All dimensions in mm, rounded, subject to technical modifications)

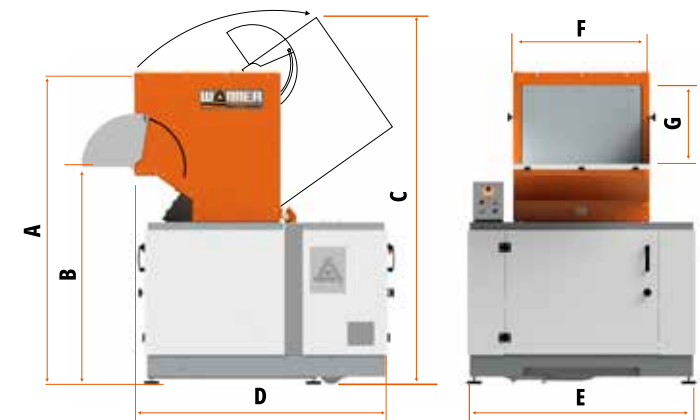



From granulator to size-reduction centre

If centralised granulating is required, our granulators from the Energy Series can easily be used to build central granulation stations for throughputs of up to 500 kg/h.

In addition to supplying you with the granulator to meet your needs, we also offer a full range of peripheral equipment, including material transport blowers with suitable tubing, cy-

clone separators with frame and the rotary wheel feeder, metal separator, and conveyor belt with or without metal detector.

In very noise-sensitive areas, it is also possible to encapsulate the entire granulator completely to allow a central set up of the system e.g. near the production areas in a hall without generating a noise issue. The air flow volume of blowers and cyclones used to convey materials is adapted and coordinated so that granulate and air is cleanly separated. The two large filter sacks ensure that the environment remains mostly undisturbed. If you have special requirements here, just let us know.

< **Granulator E 45.80 with conveyor belt feed, extended feed opening of the hopper, integrated blower, cyclone separator with rotary wheel gate, dedusting unit, and metal separator as central grinding station**



E 35.60 Special hoppers with side feed opening

For special applications, we can adapt our machines to fit our customers' needs perfectly. If for example longer profile sections need to be processed, we do make special hoppers with additional feed hopper inlet on the side. Depending on the customer's requirements, we can adapt our hoppers in any way in which material to be ground in the machine needs to be fed in. Our granulators can be well-adapted to your specific requirements for part size and throughput by using different

rotors, such as the three-edged or five-edged versions or using grinding chambers with infeed areas of different shapes. Other options, such as additional wear protection in the cutting chamber or on the blower, as well as a number of control unit options enable us to meet even the most exacting demands. No matter if it's blow-moulded parts, injection-moulded parts, or extrusion profiles – we are sure to have a solution for your granulating problem.



The Energy Series – easily accessible

The granulators in our Energy Series come standard with an integrated sound enclosure. A door that opens wide and the gas spring-supported, wide-opening feed hopper make accessing the cutting chamber quick and easy. The screen cradle can be opened without tools and the screen can also be easily removed.

Some of our customers in Swabia even call our granulators "the fast cleaning granulators" instead to Wanner granulators, because of their easy accessibility and user-friendliness. We see this name both as a compliment and a duty.



Everything integrated and easily accessible

Granulators from our Energy Series are available with an optional blower integrate into the standard sound enclosure that is easily accessible through a large back door. Incorporating the blower into the sound enclosure of the granulator sustainably dampens the noise generated. In order to save space, the blower is installed at the back in the sound enclosure and accessible through a wide opening door. The robustly designed blower itself is also hinged for easy opening.

Depending on customer requirements, the blower as well as the pipe bends can be provided in a wear-protected design, so that even fibreglass-reinforced materials can be reliably processed.

The ThermoGranulator

The compact reggranulator system



< Model TG20

The ThermoGran20 enables you to regranulate problematic plastic materials with e.g. lot of dust or non-uniform size or even small parts / sprues directly into high-quality granulate.

The granulates produced with the TG20 are of the highest quality and flow behaviour are comparable with the corresponding virgin material.

Accordingly, the granulate produced with the TG20 can be safely reused in your production process and is the right solution wherever a purely „mechanical granulation“ does not provide sufficient results for the process demands.

The system consists of a compact, slow-running extruder with a large in feed zone and a special screw geometry with a large auxiliary feed screw, so that even very poorly flowing regrind with dust, whole sprues and small parts is easily pulled in. The plastic strand is cooled down in a water bath integrated into the system and then cut off in a defined manner with the strand pelletiser, so that a very uniform, easily pourable and and easy to dose granulate is produced.

The TG 20 is equipped with a touch-screen control system that can handle even demanding processing tasks.

In automatic mode, the control can adjust the the extruder speed to the feed behaviour of the material and adjust the take-off speed of the pelletiser, so that process fluctuations can be compensated to a certain extent.

The TG20 can also be used for simple compounding applications such as colouring or for the production of micro-pellets.



Advantages:



- > Processing of small parts and very no-uniform material safely possible
- > Colouring or production of microgranulates possible
- > Processing of very dusty materials possible
- > Safe material intake due to large intake zone and a special feed screw.
- > By software coupling of the strand pelletiser with the plasticising unit, a homogeneous material is achieved even with material fluctuations.

Technical data



TG20	
Motor power extruder	4 kW
Motor power granulator	0,37 kW
No. of heating zones	3 (barrel)
Heating power	3 x 3 kW
Speed extruder	0 - 34 rpm
Output	Max. ca. 20 kg
Infeed area	Auger + auxiliary auger
Power supply	400 volts / 50 Hz
Weight	ca. 650 kg
Control	PLC



27

Dimensions TG20

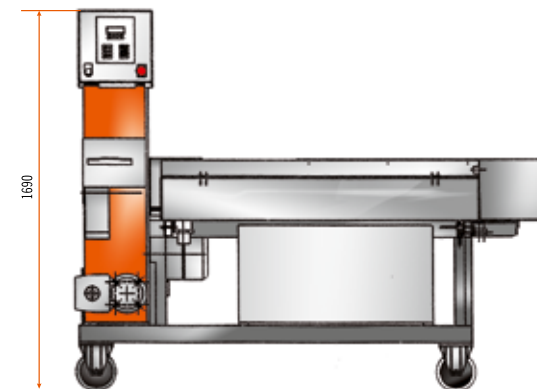
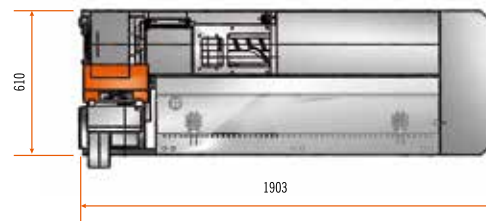

(All dimensions in mm, rounded, subject to technical modifications)

Alte Heerstraße 5
D-97877 Wertheim, Germany
Tel.: +49 93 42 / 3 08 80
info@wanner-technik.de
www.wanner-technik.de

Our granulators
in action at



Always
up-to-date



Represented by:



What drives us

Wanner-Technik GmbH has worked in the field of plastics size-reduction since the start of the 1980s.

It was during this time that we put our capabilities to the test, delivery some 10,000 granulators. Our client base consists of companies of all different sizes, from small companies through to the most well-known plastics processors in the industry.

We are driven by our mission to provide customers with the highest-quality granulating machines, while also offering an excellent price/performance ratio. The technology used for grinding machines intrigues us just as much now as it did on Day 1. This predilection for technical expertise shows

in our manufacturing. For a company of our size, we operate with an extraordinary depth of production that allows us to ensure our high standards of quality are met while also enjoying an unusually high degree of flexibility.

In our high-precision CNC centres, we product standard parts as well as special parts required for our customers' custom solutions.

Our powerful sheet metal production provides the flexibility to manufacture special hopper configurations within a short period of time. Our depth of production also gives us extensive expertise in the optimal implementation of design solutions in real

products. A capable team of highly qualified professionals is here to ensure that the machines we deliver meet the highest standards for quality.

We would like to invite you to see for yourself at our factory!